



Product Brochure

The most affordable or nothing.

Main category: Industrial robot arm / Collaborative robot arm /
Electric gripper/ Intelligent actuator/ Automation solutions



Z-EFG-20

Electric 2-Fingers Parallel Gripper



Product Features

- Built-in controller
- Adjustable stroke and gripping force
- The end can be replaced to adapt to various needs
- Pick up fragile and deformable objects such as eggs, test tubes, rings, etc.
- Apply for scenes without air source (e.g. laboratory, hospital)

Promoting a revolution in the replacement of pneumatic grippers by electric grippers

First electric gripper with integrated servo system in China

Highly Integrated

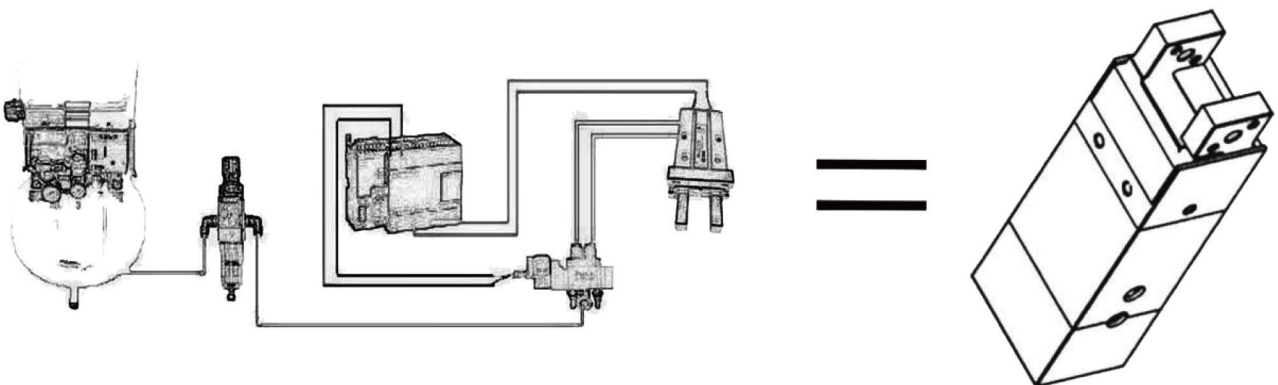

- Perfect replacement for air compressor + filter + solenoid valve + throttle valve + pneumatic gripper
- Multiple cycles service life, consistent with the traditional Japanese cylinder

Application Scenes

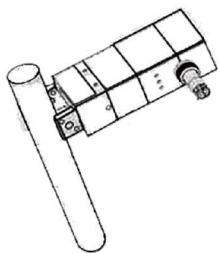

Fragile scene (e.g. test tube)

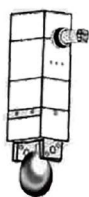

Fragile scene (e.g. eggs)

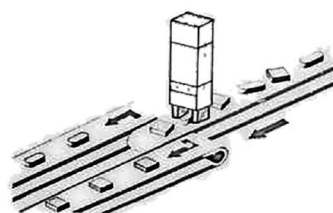

Sorting out things that are arranged in a mess

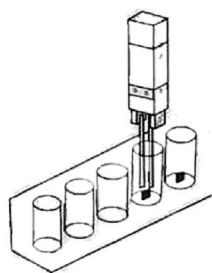

Gripping in narrow scene



Deformable scene (e.g. rings)

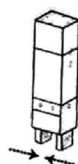

Gripping fragile items at high frequency

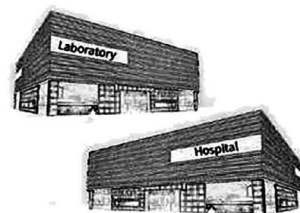

Apply for scenes without air source (e.g. laboratory, hospital)

Specification Parameters

Model No. Z-EFG-20	Parameter
Total stroke	20mm
Gripping force	80N
Repeatability	±0.02mm
Recommended gripping weight	0.8kg
Transmission mode	Gear rack + Cross roller guide
Grease replenishment of moving components	Every six months or 1 million movements / time
One-way stroke motion time	0.45s
Operating temperature range	5-55°C
Operating humidity range	RH35-80 (No frost)
Movement mode	Two fingers move horizontally
Stroke control	Adjustable
Clamping force adjustment	Adjustable
Weight	0.458kg
Dimensions (L*W*H)	44*30*124.7mm
Controller placement	Built-in
Power	5W
Motor type	DC brushless
Peak Current	1A
Rated voltage	24V
Standby current	0.2A
Impact resistant / vibration-resistant	98m/s
Motor diameter	28mm

* Z-EFG-20 gripping force: The gripping force can be adjusted by adding a controlled deformation material to the front of the fixture, which is obtained according to the corresponding curve of deformation and force.

Dimension Installation Diagram

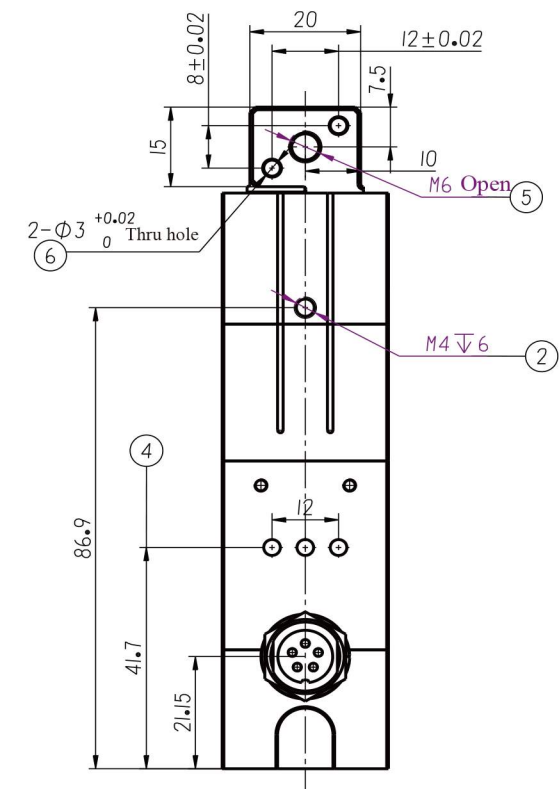
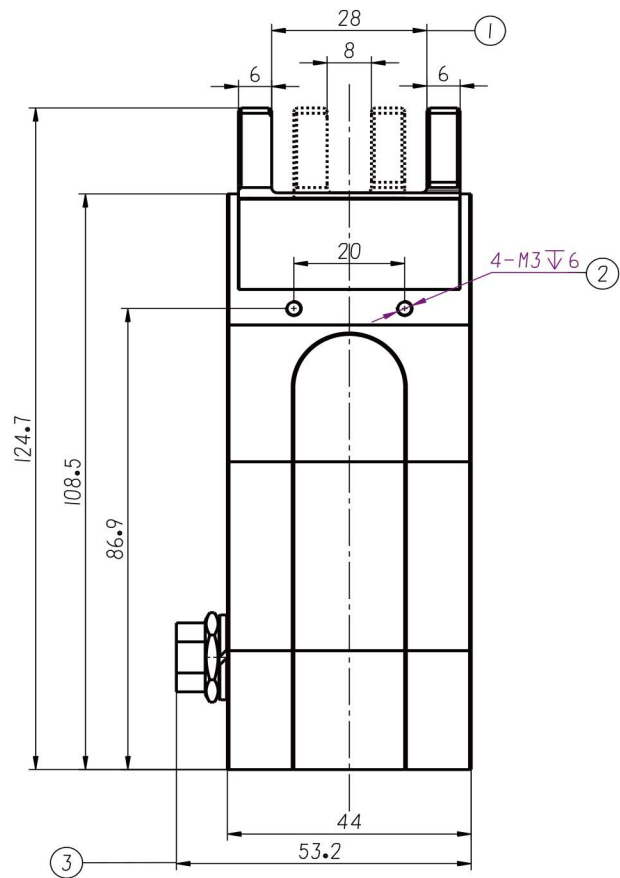
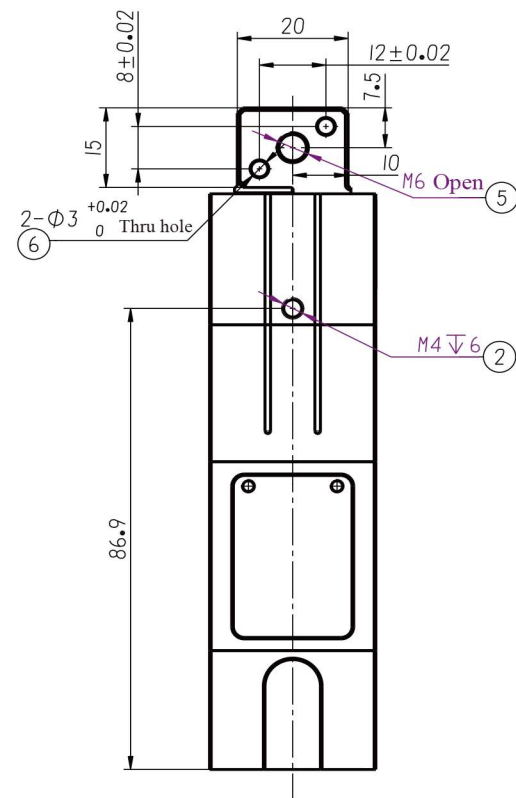

- ① Movement stroke of gripper fingers
- ② Side mounting position (threaded hole)
- ③ Aviation socket wiring location
- ④ Position of gripper adjustment force (left) and indicator light (right)
- ⑤ Gripper installation position (threaded hole)
- ⑥ Gripper installation position (pin hole)
- ⑦ Bottom mounting position (pin hole)
- ⑧ Bottom mounting position ((threaded hole)

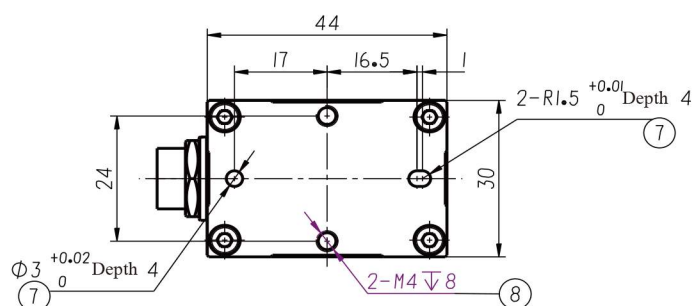

Wire Sequence Description (NM)

Aviation Plug	Black Wire	Grey Wire	Function	Usage	Remarks
1	White	White	Control signal (control clamping or loosening)	If the controller logic level is 3.3V or 5V, it can be connected directly to the I/O port <ul style="list-style-type: none"> · When inputting 0V-0.7V (low level) , and input the pulse signal at the same time, the gripper opens outwards · When inputting 2.7V-5V (high level) , and input the pulse signal at the same time, the gripper clamps inwards 	Connected required
				If the controller logic level is higher than 5V, the open drain output can be used <ul style="list-style-type: none"> · When open drain output “ Open Drain ” (not valid), and input the pulse signal at the same time, the gripper clamps inwards · When inputting 0V-0.7V (valid) , and input the pulse signal at the same time, the gripper opens outwards 	
				If the controller logic level is higher than 5V, and the second method cannot be used, a resistor can be connected in series. When the control voltage is 24V, the resistor in series is 8.2k <ul style="list-style-type: none"> · When the input is higher than 2.7V (high level) , the gripper clamps inwards. · When inputting 0-VLow* (low level) , the gripper opens outwards 	
2	Pink	Red	+24V	Power supply	Connected required
3	Yellow	Yellow	Input Pulse	<ul style="list-style-type: none"> · Connection method and high / low level definition are the same as port 1 (control signal) · Input 0~200 pulses, control the gripper to travel 0-20mm, each pulse travel 0.1mm · Maximum input 200 pulses, 10mm on each side, the highest frequency is 5KHz 	Connected required
4	Orange	Green	Feedback pulse	<ul style="list-style-type: none"> · Read-only output, selective connected · The pulse is 0V, 3.3V pulse feedback, the effective level time is 100us, and it is related to the gripper stroke, each 0.1mm inward/outward travel, one pulse feedback · The high and low level time is not less than 200us, 1KHz corresponds to the maximum speed, frequency more than 1KHz, less than 5KHz time, still perform 1KHz 	Selective connection
5	Grey	Black	GND	Power supply	Connected required

* Description

After power on, the gripper will open to the maximum position (initialization) .

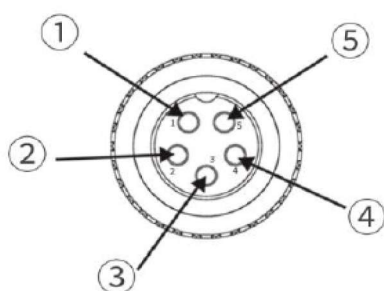

- ① Control signal
- ② +24V
- ③ Input pulse
- ④ Feedback pulse
- ⑤ GND

Diagram of aviation plug female port

Wire Sequence Description (NK)

Aviation Plug	Black Wire	Grey Wire	Function	Usage	Remarks
1	White	White	Control signal	If the controller logic level is 3.3V or 5V, it can be connected directly to the I/O port When 1 and 3 control signals are high or low at the same time, the gripper has no action 1 high level, 3 low level as gripper opens 3 high level, 1 low level as gripper closes	Connected required
				<ul style="list-style-type: none"> · When inputting 0V~0.7V (low level) · When inputting 2.7V~5V (high level) If the controller logic level is higher than 5V, the open drain output can be used <ul style="list-style-type: none"> · When open drain output “Open Drain” (invalid) · When inputting 0V-0.7V (valid) 	
				If the controller logic level is higher than 5V, and the second method cannot be used, a resistor can be connected in series When the control voltage is 24V, the resistor in series is 8.2k <ul style="list-style-type: none"> · When the input is higher than 2.7V (high level) · When inputting 0-V_{Low}* (low level) 	
2	Pink	Red	+24V	Power supply	Connected required
3	Yellow	Yellow	Control signal	Same control mode as port 1	Connected required
4	Orange	Green	Feedback signal	<ul style="list-style-type: none"> · Selective connection, read-only and display the status of LED · Output 3.3V when in motion, output 0V when motion ends 	Selective connection
5	Grey	Black	GND	Power supply	Connected required

* Description

1. $V_{Low} \leq 0.7 - 2.6 * R_x / 50K$;
2. After power on, the gripper will open to the maximum position (initialization) .

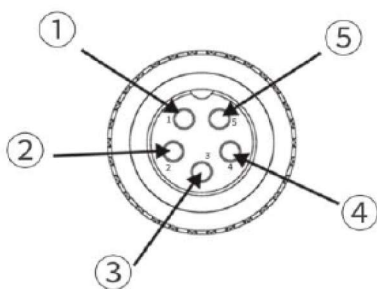

- ① Control signal
- ② +24V
- ③ Control signal
- ④ Feedback signal
- ⑤ GND

Diagram of aviation plug female port

Wire Sequence Description (PM)

Aviation Plug	Black Wire	Grey Wire	Function	Usage	Remarks
1	White	White	Control signal (control clamping or loosening)	PLC uses 24V, PNP output mode, directly connected to I/O port. <ul style="list-style-type: none"> · If the input collector is open, the gripper opens outwards · when inputting 19~24V (high level) , the gripper clamps inwards · Input current <5mA 	Connected required
				If the controller logic level is 24V <ul style="list-style-type: none"> · When inputting 19~24V (high level) , the gripper clamps inwards · When inputting 0~12V (low level) , the gripper opens outwards · Input current <5mA 	
2	Pink	Red	24V	Power supply	Connected required
3	Yellow	Yellow	Feedback pulse	<ul style="list-style-type: none"> · Read-only output, selective connected · output 0V as low level · Output 24V as high level · Output structure is NPN internal pull-up to 24V 	Selective connection
4	Orange	Green	Input Pulse	<ul style="list-style-type: none"> · Connection method and high / low level definition are the same as port 1 (control signal) · Input 0~200 pulses, control the gripper to travel 0-20mm, each pulse travel 0.1mm · Maximum input 200 pulses, 10mm on each side · maximum pulse frequency should not exceed 5KHz · 1KHz corresponds to the maximum speed, when the frequency exceeds 1KHz and is less than 5KHz, the maximum speed of 1KHz is still executed 	Connected required
5	Grey	Black	GND	Power supply	Connected required

* Description

After power on, the gripper will open to the maximum position (initialization) .

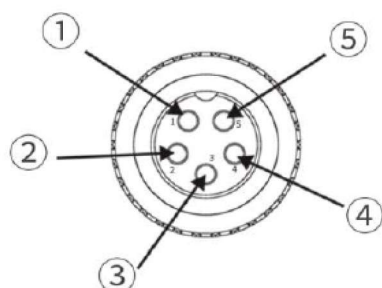

- ① Control signal
- ② +24V
- ③ Feedback pulse
- ④ Input pulse
- ⑤ GND

Diagram of aviation plug female port

Wire Sequence Description (PK)

Aviation Plug	Black Wire	Grey Wire	Function	Usage	Remarks
1	White	White	Control signal	PLC uses 24V, PNP output mode, directly connected to I/O port ·When 1 and 4 control signals are high or low at the same time, the gripper has no action ·1, high level 4, low level as gripper closes ·4, high level 1, low level as gripper opens If the controller logic level is 24V ·When inputting 19~24V (high level) ·When inputting 0~12V (low level) ·Input current <5mA	Connected required
2	Pink	Red	24V	Power supply	Connected required
3	Yellow	Yellow	Feedback signal	·Selective connection, read-only and display the status of LED ·Output 24V when in motion (internal pull-up 4.7K resistor to 24V) , output 0V when motion ends	Selective connection
4	Orange	Green	Control	Same control mode as port 1	Connected required
5	Grey	Black	GND	Power supply	Connected required

* Description

After power on, the gripper will open to the maximum position (initialization) .

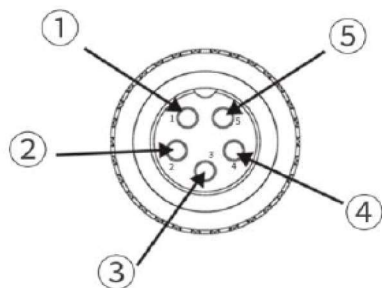

- ① Control signal
- ② +24V
- ③ Feedback signal
- ④ Control signal
- ⑤ GND

Diagram of aviation plug female port

Electrical Parameters

- Rated voltage 24±2V
- Current 0.4A

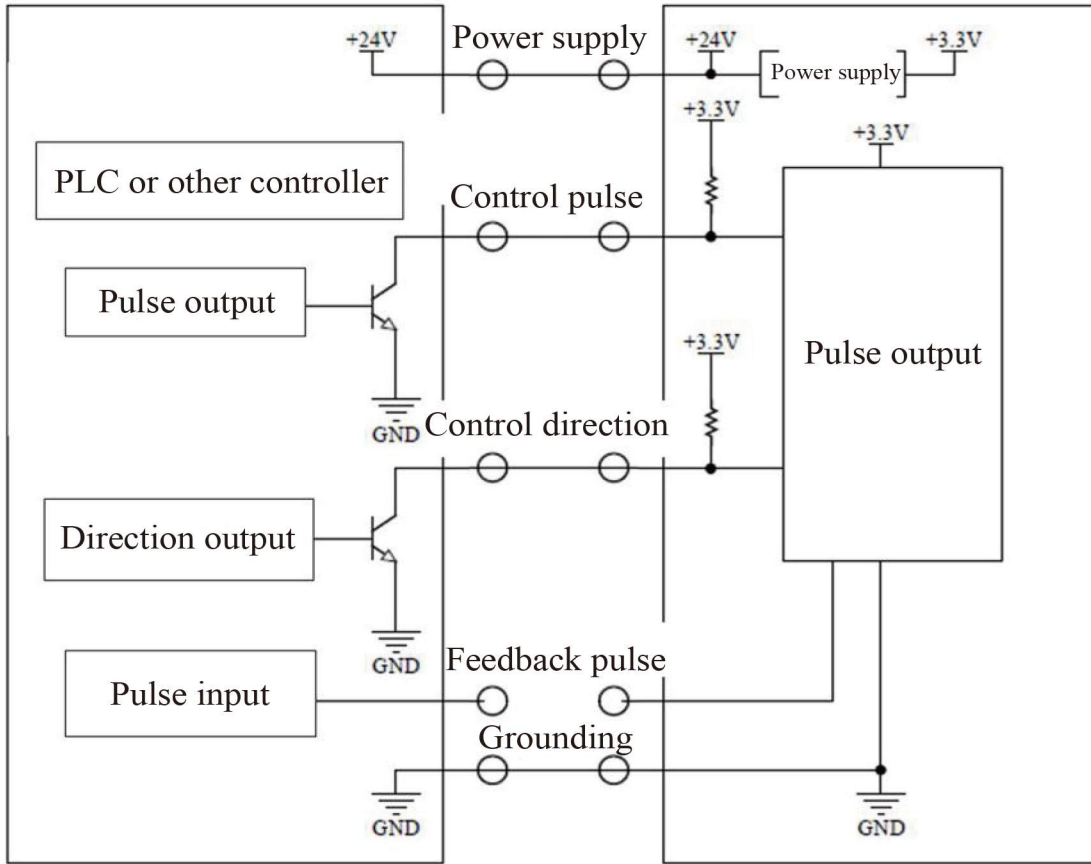

Physical Diagram

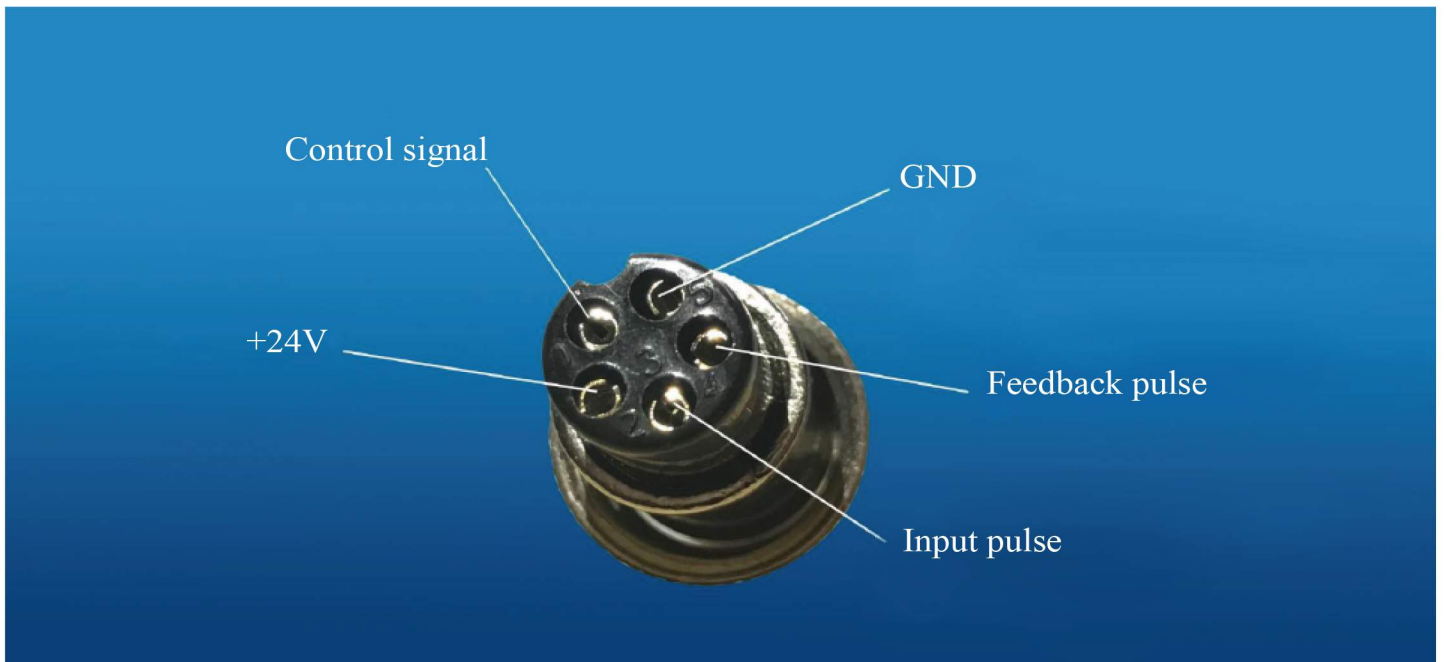

FAQ

1. There is a requirement for the concentricity of rotation, so when the two sides of the gripper are close, does it stop at the middle position each time?

Answer: Yes, there is a symmetry error of $<0.1\text{mm}$, and the repeatability is $\pm 0.02\text{mm}$.

2. Does the gripper include the fixture part?

Answer: No. Users need to design their own fixture part according to the actual clamped items. In addition, Hitbot provides a few fixture libraries, please contact our staff for more details.

3. Where is the drive controller and do I need to pay extra money for it?

Answer: It is built-in, no extra charge, the amount of the gripper already includes the cost of controller.

4. Is it possible to have a single finger movement?

Answer: No, single finger movement grippers are still under development, please contact our staff for more details.

5. What is the operating speed of Z-EFG-20?

Answer: Z-EFG-20 takes 0.45s for a full stroke in one direction and 0.9s for a round trip.

6. What is the gripping force of Z-EFG-20 and how to adjust it?

Answer: The clamping force of Z-EFG-20 can be obtained according to the corresponding curve of deformation and force due to the addition of controllable deformation material in front of the fixture.

7. How to adjust the stroke of Z-EFG-20?

Answer: 200 pulses correspond to a 20mm stroke, and 1 pulse corresponds to a 0.1mm stroke.

8. The gripper of Z-EFG-20 has a stroke of 20mm corresponding to 200 pulses. What will happen if 300 pulses are sent?

Answer: The extra pulse will not be executed and has no effect.

9. The gripper of Z-EFG-20 has a stroke of 20mm corresponding to 200 pulses. If 200 pulses are sent, but the gripper clamp things after reaching 100 pulses, will it stop after clamping things and the remaining 100 pulses continue to be sent? Does it have any effect?

Answer: The remaining pulses will not be executed and have no effect.

10. How to judge whether the grippers is holding something or not?

Answer: For Z-EFG-20, the number of feedback pulses reflects the current position of the gripper, so the user can judge whether the object is clamped by counting the feedback pulses.

11. Is the electric gripper waterproof ?

Answer: IP protection class 20.

12. What kind of motor is used in Z-EFG-20?

Answer: Servo motor.

13. Is it possible to use Z-EFG-8S or Z-EFG-20 gripper for gripping items larger than 20mm?

Answer: Yes, 8mm and 20mm refer to the effective stroke, not the size of the object to be clamped. Z-EFG-8S can be used to clamp objects with the maximum to minimum size difference within 8mm. The Z-EFG-20 can be used for clamping objects with the maximum to minimum size difference within 20mm.

14. If it keeps working, will the motor of the electric gripper overheat?

Answer: After professional testing, the surface temperature of Z-EFG-20 will not exceed 60 degrees when clamping continuously at a temperature of about 30 degrees.

The most affordable or nothing.



Huiling-tech Robotic Co.,Ltd.

Tel: 0755-36382405 Hotline: (0086) 18926780705

Email: support@hitbotrobot.com

Website: <https://www.hitbotrobot.com>

Address: 2nd Floor, Building E, Huafeng International Robot Industrial Park, Hangcheng Ave,
Xixiang St, Baoan District, Shenzhen City, Guangdong Province, China